



Refrigerated Showcase
Model RS-CN-0200
Item 31809
Instruction Manual



Revised - 08/30/2022



Toll Free: 1-800-465-0234
Fax: 905-607-0234
Email: service@omcan.com
www.omcan.com

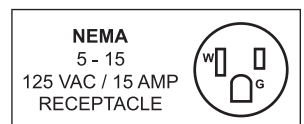

Table of Contents

Model RS-CN-0200

Section	Page
Disclaimer -----	3
General Information -----	4 - 5
Safety and Warranty -----	5 - 6
Technical Specifications -----	7
Installation -----	7 - 9
Operation -----	9 - 10
Maintenance -----	10
Troubleshooting -----	10 - 11
Parts Breakdown -----	14
Electrical Schematics -----	15
Notes -----	16 - 18
Warranty Registration -----	19

Disclaimer

OMCAN IS NOT RESPONSIBLE FOR DIMINISHED COOLING OR ANY DAMAGES DUE TO WATER LEAKS. WARRANTY IS VOID IF THE AMBIENT ROOM TEMPERATURE EXCEEDS 75°F AND 55% RELATIVE HUMIDITY, AND THE APPLIANCE DRAIN IS NOT CONNECTED DIRECTLY TO A FLOOR DRAIN.

General Information

Omcan Manufacturing and Distributing Company Inc., Food Machinery of America, Inc. dba Omcan and Omcan Inc. are not responsible for any harm or injury caused due to any person's improper or negligent use of this equipment. The product shall only be operated by someone over the age of 18, of sound mind, and not under the influence of any drugs or alcohol, who has been trained in the correct operation of this machine, and is wearing authorized, proper safety clothing. Any modification to the machine voids any warranty, and may cause harm to individuals using the machine or in the vicinity of the machine while in operation.

CHECK PACKAGE UPON ARRIVAL

Upon receipt of an Omcan shipment please inspect for external damage. If no damage is evident on the external packaging, open carton to ensure all ordered items are within the box, and there is no concealed damage to the machine. If the package has suffered rough handling, bumps or damage (visible or concealed), please note it on the bill of lading before accepting the delivery and contact Omcan within 24 hours, so we may initiate a claim with the carrier. A detailed report on the extent of the damage caused to the machine must be filled out within three days, from the delivery date shown in the shipping documents. Omcan has no recourse for damaged products that were shipped collect or third party.

Before operating any equipment, always read and familiarize yourself with all operation and safety instructions.

Omcan would like to thank you for purchasing this machine. It's of the utmost importance to save these instructions for future reference. Also save the original box and packaging for shipping the equipment if servicing or returning of the machine is required.

Omcan Fabrication et distribution Compagnie Limitée et Food Machinery d'Amérique, dba Omcan et Omcan Inc. ne sont pas responsables de tout dommage ou blessure causé du fait que toute personne ait utilisé cet équipement de façon irrégulière. Le produit ne doit être exploité que par quelqu'un de plus de 18 ans, sain d'esprit, et pas sous l'influence d'une drogue ou d'alcool, qui a été formé pour utiliser cette machine correctement, et est vêtu de vêtements de sécurité appropriés. Toute modification de la machine annule toute garantie, et peut causer un préjudice à des personnes utilisant la machine ou des personnes à proximité de la machine pendant son fonctionnement.

VÉRIFIEZ LE COLIS DÈS RÉCEPTION

Dès réception d'une expédition d'Omcan veuillez inspecter pour dommages externes. Si aucun dommage n'est visible sur l'emballage externe, ouvrez le carton afin de s'assurer que tous les éléments commandés sont dans la boîte, et il n'y a aucun dommage dissimulé à la machine. Si le colis n'a subi aucune mauvaises manipulations, de bosses ou de dommages (visible ou cachée), notez-le sur le bond de livraison avant d'accepter la livraison et contactez Omcan dans les 24 heures qui suivent, pour que nous puissions engager une réclamation auprès du transporteur. Un rapport détaillé sur l'étendue des dommages causés à la machine doit être rempli dans un délai de trois jours, à compter de la date de livraison indiquée dans les documents d'expédition. Omcan n'a aucun droit de recours pour les produits endommagés qui ont été expédiés ou cueilli par un tiers transporteur.



General Information

Avant d'utiliser n'importe quel équipement, toujours lire et vous familiariser avec toutes les opérations et les consignes de sécurité.

Omcan voudrais vous remercier d'avoir choisi cette machine. Il est primordial de conserver ces instructions pour une référence ultérieure. Également conservez la boîte originale et l'emballage pour l'expédition de l'équipement si l'entretien ou le retour de la machine est nécessaire.

Omcan Empresa De Fabricacion Y Distribucion Inc. Y Maquinaria De Alimentos De America, Inc. dba Omcan y Omcan Inc. no son responsables de ningun daño o perjuicio causado por cualquier persona inadecuada o el uso descuidado de este equipo. El producto solo podra ser operado por una persona mayor de 18 años, en su sano juicio y no bajo alguna influencia de droga o alcohol, y que este ha sido entrenado en el correcto funcionamiento de esta máquina, y ésta usando ropa apropiada y autorizada. Cualquier modificación a la máquina anula la garantía y puede causar daños a las personas usando la máquina mientras esta en el funcionamiento.

REVISE EL PAQUETE A SU LLEGADA

Tras la recepcion de un envio Omcan favor inspeccionar daños externos. Si no hay daños evidentes en el empaque exterior, Habra el carton para asegurarse que todos los articulos solicitados estén dentro de la caja y no encuentre daños ocultos en la máquina. Si el paquete ha sufrido un manejo de poco cuidado, golpes o daños (visible o oculto) por favor anote en la factura antes de aceptar la entrega y contacte Omcan dentro de las 24 horas, de modo que podamos iniciar una reclamación con la compañía. Un informe detallado sobre los daños causados a la máquina debe ser llenado en el plazo de tres días, desde la fecha de entrega que se muestra en los documentos de envío. Omcan no tiene ningun recurso por productos dañados que se enviaron a recoger por terceros.

Antes de utilizar cualquier equipo, siempre lea y familiarizarse con todas las instrucciones de funcionamiento y seguridad.

Omcan le gustaría darle las gracias por la compra de esta máquina. Es de la mayor importancia para salvar estas instrucciones para futuras consultas. Además, guarda la caja original y el embalaje para el envío del equipo si servicio técnico o devolución de la máquina que se requiere.

Safety and Warranty

SUITABLE FOR HIGH TRAFFIC AREAS WHERE NOISE LEVELS ARE NOT A CONCERN.

RESIDENTIAL USERS: Vendor assumes no liability for parts or labor coverage for component failure or other damages resulting from installation in non-commercial or residential applications. The right is reserved to deny shipment for residential usage; if this occurs, you will be notified as soon as possible.

Safety and Warranty

1 YEAR PARTS AND LABOUR WARRANTY

Within the warranty period, contact Omcan Inc. at 1-800-465-0234 to schedule an Omcan authorized service technician to repair the equipment locally.

Unauthorized maintenance will void the warranty. Warranty covers electrical and part failures, not improper use.

Please see <https://omcan.com/disclaimer> for complete info.

WARNING:

The packaging components are classified as normal solid urban waste and can therefore be disposed of without difficulty.

In any case, for suitable recycling, we suggest disposing of the products separately (differentiated waste) according to the current norms.

DO NOT DISCARD ANY PACKAGING MATERIALS IN THE ENVIRONMENT!

Technical Specifications

Model	RS-CN-0200
Power	1280 W
Electrical Heating Element	450 W
Capacity	200 L / 7.06 cu.ft.
Electrical	110V / 60Hz / 1
Lamp Power	2.8 W x 3 (LED)
Temperature Range	2 - 10°C / 35.6 - 50°F
Max Ambient Temp Rating	24°C / 75°F
Refrigerant and Injection	R290 (148g)
Blowing Gas	N/A
Type of Climate	6
Rated Current	14.5A
Shelf Size	37.2" x 9.45" / 945 x 240mm
Shelf Load Capacity	33.1 lbs. / 15 kgs.
Dimensions	39.4" x 25" x 49.2" / 1000 x 635 x 1250mm
Weight	253.5 lbs. / 115 kgs.
Packaging Dimensions	42.3" x 27.6" x 55.1" / 1075 x 700 x 1400mm
Packaging Weight	286.6 lbs. / 130 kgs.
Item Number	31809

Installation

HANDLE AND ASSEMBLING



Handle with care

Unplug wall socket before moving. Never tilt the refrigerator over 45 degrees during handling.



Storage

Always store refrigerator in a dry place.

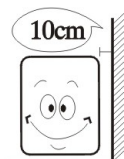

Sufficient space

To allow for proper air circulation and increased refrigeration capabilities, the refrigerator must have at least 3 inches of space between wall and unit.

Installation

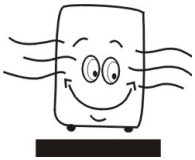

Proper ventilation

Always place the refrigerator in an area with good ventilation. For first time use, wait at least 2 hours before plugging into wall socket.

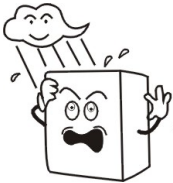

X Away from heat source

Never place the refrigerator near any type of heat source or in direct sunlight, as it reduces refrigeration capabilities.



X No heavy load

Never put heavy items on top of the refrigerator.

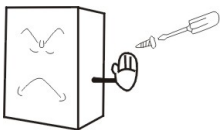

No alterations/tampering

Never tamper with, or make changes to the refrigerator. Changes and add-ons should not be installed to the inside or outside of the refrigerator.

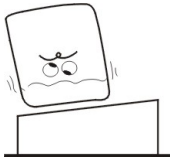

Stable location

Unpack and place the refrigerator on flat, solid ground.

PREPARATION AND POWER SUPPLY

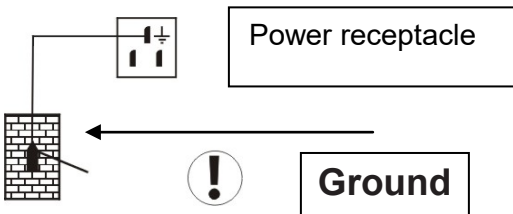

Exclusive power socket

Power supply should be 110V, single phase AC with exclusive single phase three pin outlet and fuse (8A). The power outlet must be in close proximity to the ground.

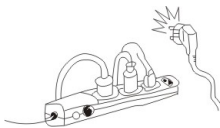

No shared power outlets

Refrigerator cable should never share the power outlet with any other appliance, as cable will overheat and may result in a fire.

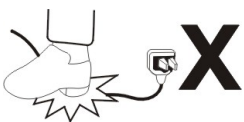

X Protect cables



Extra caution should be used when handling cables, as broken or damaged cables can cause sparking and may result in a fire.







X No water flushing

Never flush the refrigerator surface. This can cause leakage, which may result in electrical damage or fire.

Installation

  **X** **Never store flammables and explosives**
No explosives or flammables should be stored in, or in proximity to, the refrigerator, such as gasoline, alcohol, and adhesives.

  **X** **No spray**
Never spray flammables such as paint or coating near the refrigerator. This may cause fire or malfunction.

  **After power outage**
After a power outage or the unplugging of the refrigerator, wait at least 5 minutes before plugging it back in.

 **X** **No medicine**
Medicine should not be stored inside of the refrigerator.

Operation

USE AND CAUTION

Before use:

- Plug refrigerator into the 110V exclusive socket.
- After the refrigerator is running, confirm that air suction/filtration is in order and that it is sufficiently cold. After checking to make sure the refrigerator is working properly, it may be used.
- This appliance is not intended for use by persons (including children) with reduced physical, sensory or mental capabilities, or lack of experience and knowledge, unless they have been given supervision or instruction concerning use of the appliance by a person responsible for their safety.
- Children should be supervised to ensure that they do not play with the appliance.
- The operation manual is not suitable for the persons (including children) with reduced physical, sensory or mental capabilities, or lack of experience and knowledge.

DIGITAL TEMPERATURE CONTROLLER

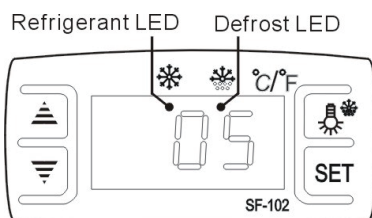





Operation

Features Of Function

Small, integrated digital controller, which is applicable to the compressor of 1 HP.

Main functions are: Temperature Display/Temperature Control/Manual-Automatic Defrost by burning off/ Lighting Control/Value Storing/Self-Testing/Parameter Locking.

Front Panel Operation

1. Set temperature: Press "SET" button; set temperature will be displayed. Press  or  button to modify and store the displayed value. Press "SET" button to exit the adjustment and display the cold-room temperature.
2. If no button is pressed within 10 seconds, the cold-room temperature will be displayed.
3. Lighting: Press  button to activate light in refrigerator; press again to turn off.
4. Manual start/stop defrost: Press  button and hold for 6 seconds to either defrost or to stop defrost.
5. Refrigeration LED: During refrigeration, the LED is on. When the cold room temperature is constant, the LED is off. During delay start, the LED flashes.
6. Defrost LED: During defrosting, the LED is on. When it stops defrosting, the LED is off. During the delay of defrost, the LED flashes.

Maintenance

1. Cabinet Cleaning: The product should be cleaned once a week with power supply disconnected. In cleaning, please use mild-rinsing water or non-corrosive products. Do not wash directly with water faucet.
2. De-Dusting for Condenser: The condenser should be cleaned every three months with power supply disconnected. To clean condenser, remove rear metal cover and get rid of any dust found on the cooling fin of the condenser using a wire brush or high-pressure air gun.
3. Leak Check: Observe all connectors and welding joints for oil stain, which indicates a need for patching work, which can be done by professionals.
4. Frequently observe the operation of the product. In case of any abnormal noise or smell, cut off the power supply immediately and call professionals. Do not restart the product before source of trouble is found.
5. We will not be responsible for any accidents acquired through failure to follow previous notices.

Troubleshooting

Troubles	Causes	Solutions
Unusual noise under the bottom shelf.	Fan blade broken.	Power off and fix the blade.

Troubleshooting

Non-refrigerating in spite of normal operation.	Unit off.	Power on.
	Melting process.	Stop melting.
	Refrigerant leaking.	Patch the leak and refill refrigerant.
	Unit failure.	Call for professionals.
Weak air from air curtain, and higher cabinet temperature.	Evaporator blocked by frost.	Increase melting frequency.
	Inside fan damaged.	Replace the fan.
	Too low set point of temperature controller.	Adjust the set point.
	Vent blocked by storage.	Remove the storage.
Normal air curtain, but higher cabinet temperature.	Insufficient refrigerant.	Refill the refrigerant.
	Too high set point of temperature controllers.	Adjust the set point for the temperature controller.
	The wind curtain disturbed by strong air flow.	Removing the disturbing factors.
	Ambient temperature or humidity beyond standards.	Improve the conditions.
Melting water overflown.	Heating pipe for melting water damaged.	Replace the heating pipe.
	Water-level controller failure.	Replace the water-level controller.
	Ambient temperature or humidity beyond standards.	Improve the conditions.
Normal air curtain, but periodical fluctuation of cabinet temperature.	Condenser contaminated.	Clean the condenser.
	Poor venting of the unit.	Improve the venting conditions.
	Heat protection of compressor failure.	Replace the heat protection.
	Capillary is blocked by ice.	Replace the drying filter.
	Temperature controller failure.	Replace the temperature controller.

Parts Breakdown

Model RS-CN-0200 31809

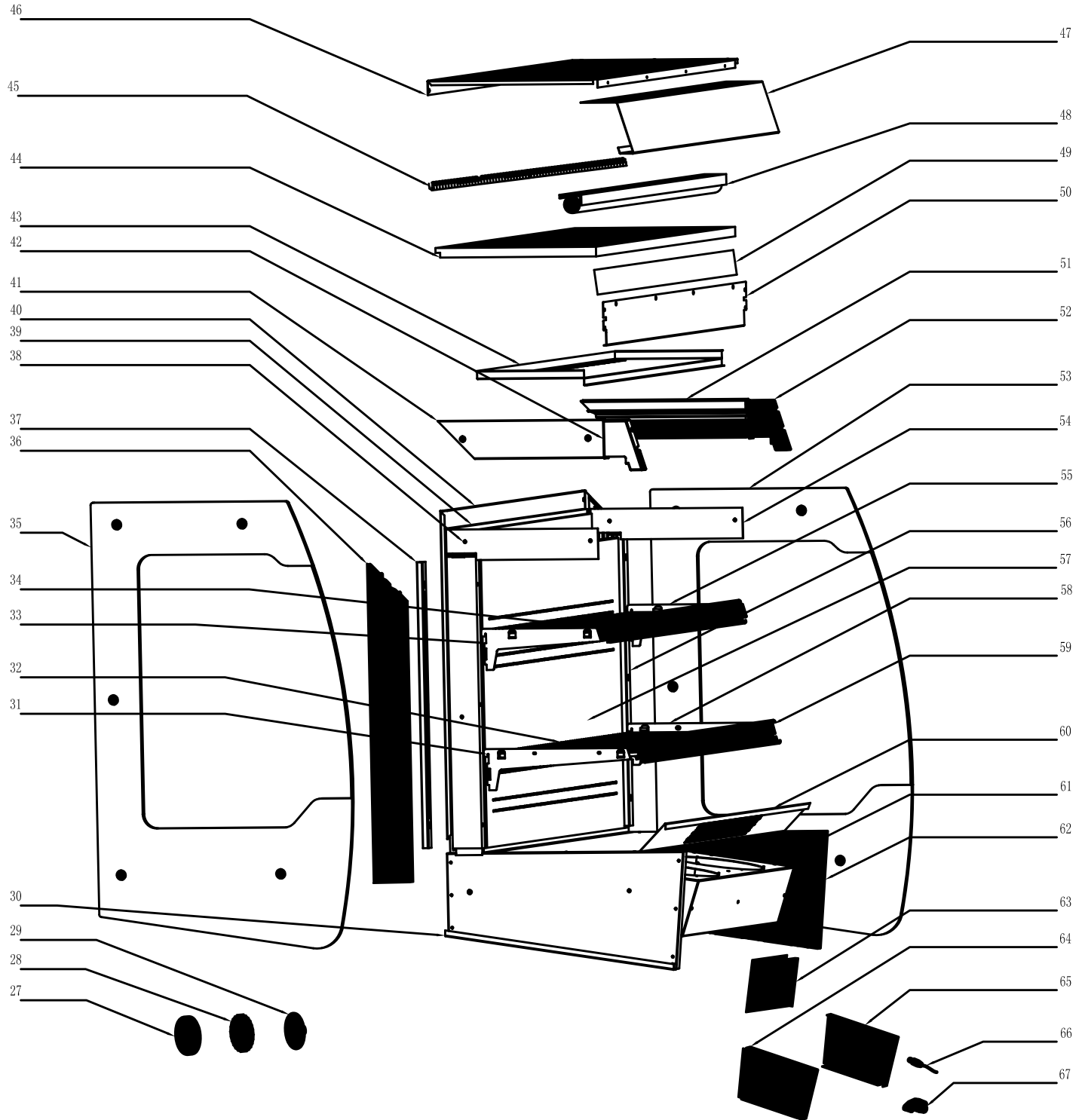

Parts Breakdown

Model RS-CN-0200 31809

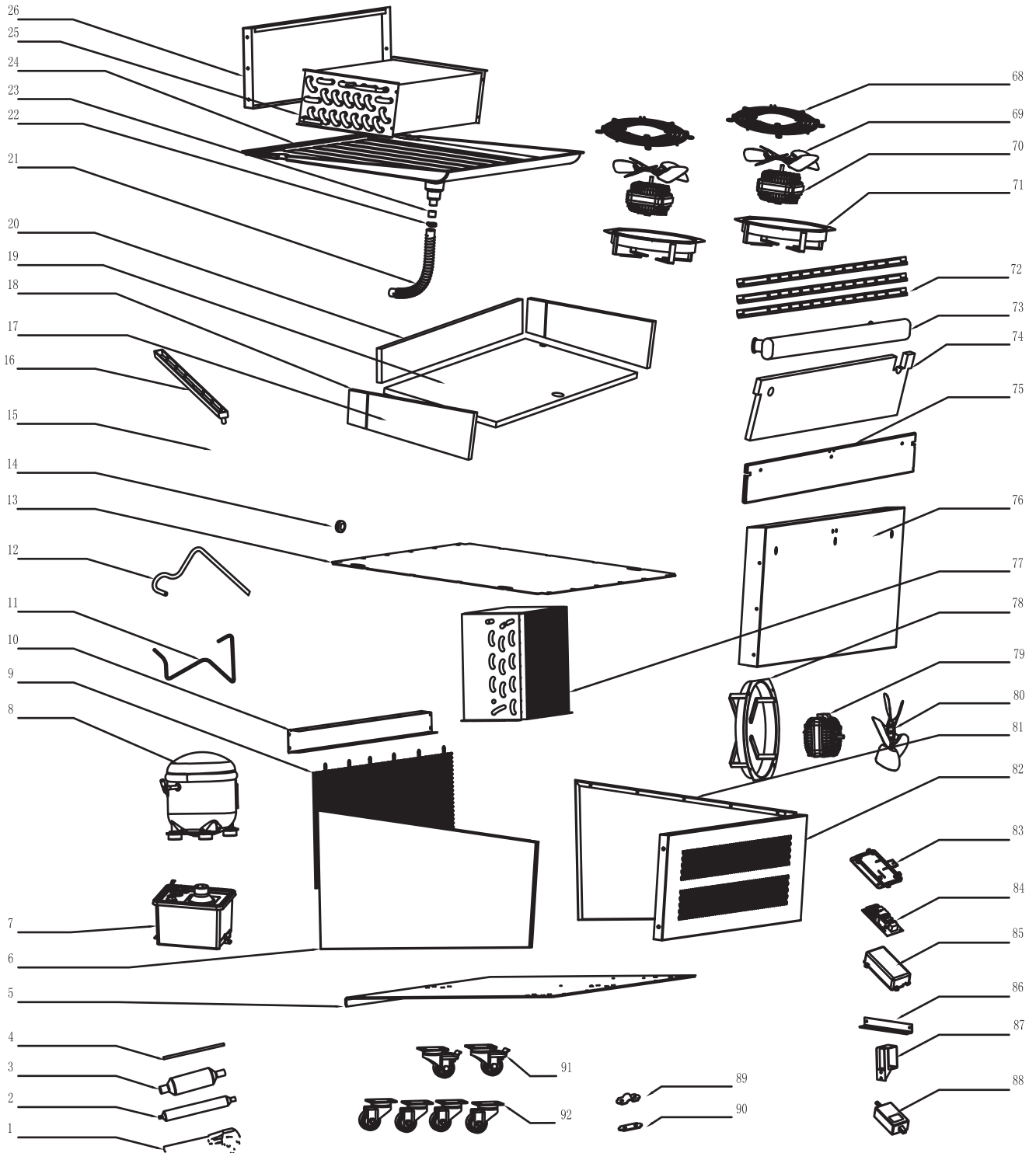

Parts Breakdown

Model RS-CN-0200 31809

Item No.	Description	Position	Item No.	Description	Position	Item No.	Description	Position
68535	Power Cord for 31809	1	68557	Bottom Shelf for 31809	32	68585	Wind Deflector for 31809	63
61224	Dry Filter for 31809	2	79322	Left Shelf Bracket for 31809	33	68586	Left Board of Motor Bracket for 31809	64
68536	Accumulator for 31809	3	68558	Top Shelf for 31809	34	70662	Cabinet Frame for 31809	65
60143	Filling Pipe for 31809	4	68559	Left Glass for 31809	35	68587	Waterproof Plug for 31809	66
68537	Base Board for 31809	5	68560	Left Rear Pillar for 31809	36	68588	Waterproof Plug for 31809	66
68538	Left Bottom Base Panel for 31809	6	68561	Pole for Shelf for 31809	37	68589	LED Socket Bracket for 31809	67
68539	Components of the Water Box for 31809	7	68562	Reinforcement for Top Left Pillar for 31809	38	68590	Fan Blade of Evaporator for 31809	68
61249	Compressor for 31809	8	68563	Rear Body Board Foam for 31809	39	71565	Fan Blade for 31809	69
68540	Rear Cover of Base for 31809	9	68564	Rear Body Board for 31809	40	AG596	Evaporator Fan Motor 110V for 31809	70
68541	Beam of Base for 31809	10	68565	Top Left Pillar for 31809	41	71564	Fan Guard for 31809	71
68542	Connecting Pipe 1 for 31809	11	68566	Left Bracket of Front Board for 31809	42	68591	LED Lamp for 31809	72
68452	Connection Pipe for 31809	12	68567	Inside Top Board for 31809	43	68592	Handle for 31809	73
68543	Shelf of Base for 31809	13	68568	Top Cover Foam for 31809	44	68593	Evaporator Front Foam for 31809	74
68544	Wire Ring for 31809	14	68569	Perforated Plate for 31809	45	68594	Handle Stiffener for 31809	75
68545	Water Chute of Left Glass for 31809	15	68570	Top Cover for 31809	46	68595	Front Top Base Panel for 31809	76
68546	Water Chute of Right Glass for 31809	16	68571	Front Board of Top Cover for 31809	47	68596	Condenser for 31809	77
68547	Side Front Foam of the Evaporator for 31809	17	68572	Curtain for 31809	48	79365	Fan Guard for 31809	78
68548	Side Rear Foam of the Evaporator for 31809	18	68573	Insulating Foam for 31809	49	AD518	Condenser Fan Motor for 31809	79
68549	Insulating Foam for 31809	19	68574	Front Board of Curtain for 31809	50	79366	Fan Blade for 31809	80
68550	Plastic Base of Evaporator for 31809	20	68575	Top Right Pillar for 31809	51	68597	Right Bottom Base Panel for 31809	81
63459	Hose Fitting (Metal) for 31809	21	68576	Left Bracket of Front Board for 31809	52	68598	Front Bottom Base Panel for 31809	82
68551	Circlip for 31809	22	68577	Right Glass for 31809	53	68599	Bottom Cover of Set-Up Box for Mainboard for 31809	83
68552	Bush for 31809	23	68578	Reinforcement for Top Right Pillar for 31809	54	68600	Main Circuit Board Complete with Probe and Display Panel for 31809	84
68553	Plastic Base for Evaporator for 31809	24	79336	Right Shelf Bracket for 31809	55	68601	Top Cover of Set-Up Box for Mainboard for 31809	85
68554	Evaporator for 31809	25	68579	Right Rear Pillar for 31809	56	68602	Control Box Bracket for 31809	86
68555	Decorative Cover of Screw Nut for 31809	26	68580	Ventilated Board for 31809	57	68603	Power Clip for 31809	87
79312	Nut Decoration for 31809	27	30750	Right Shelf Bracket for 31809	58	68604	Switch of LED Lamp for 31809	88
79313	Nut Gasket for 31809	28	68581	Label Board for 31809	59	61245	Wire Clip Cover for 31809	89
79314	Decoration Nut Gasket for 31809	29	68582	Top Cover of Base for 31809	60	61246	Wire Clip Holder for 31809	90
68556	Left Top Base Panel for 31809	30	68583	Evaporator Bracket for 31809	61	60562	Front Wheels for 31809	91
30747	Left Shelf Bracket for 31809	31	68584	Right Top Base Panel for 31809	62	60561	Rear Wheels for 31809	92

Electrical Schematics

Model RS-CN-0200 31809

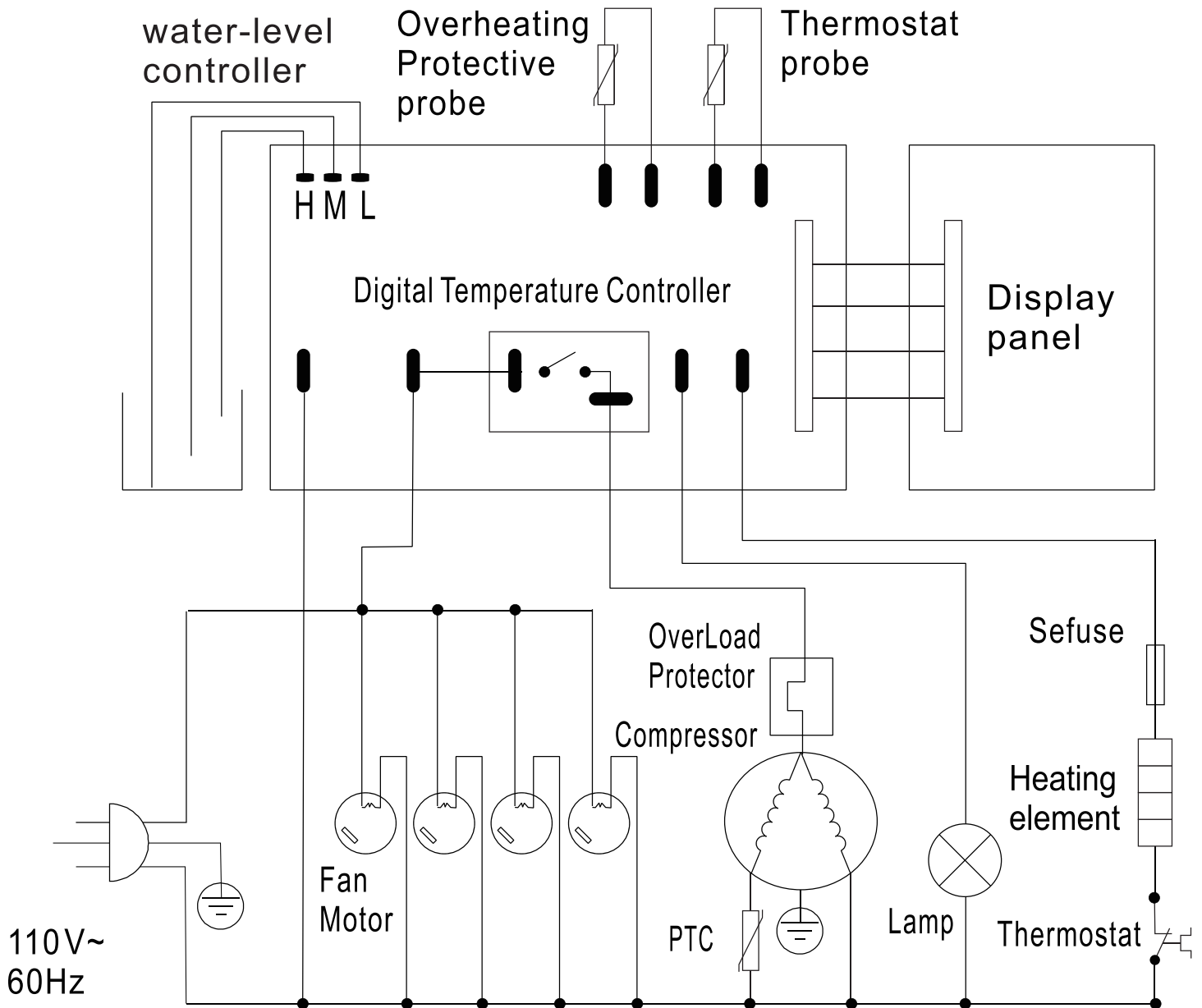

Notes



Warranty Registration

Thank you for purchasing an Omcan product. To register your warranty for this product, complete the information below, tear off the card at the perforation and then send to the address specified below. You can also register online by visiting:

Merci d'avoir acheté un produit Omcan. Pour enregistrer votre garantie pour ce produit, complétez les informations ci-dessous, détachez la carte au niveau de la perforation, puis l'envoyer à l'adresse spécifiée ci-dessous. Vous pouvez également vous inscrire en ligne en visitant:

Gracias por comprar un producto Omcan usted. Para registrar su garantía para este producto, complete la información a continuación, cortar la tarjeta en la perforación y luego enviarlo a la dirección indicada a continuación. También puede registrarse en línea en:

<https://omcan.com/warranty-registration/>

For mailing in Canada

Pour postale au Canada

Por correo en Canadá

OMCAN

PRODUCT WARRANTY REGISTRATION

3115 Pepper Mill Court,

Mississauga, Ontario

Canada, L5L 4X5

For mailing in the US

Pour diffusion aux États-Unis

Por correo en los EE.UU.

OMCAN

PRODUCT WARRANTY REGISTRATION

4450 Witmer Industrial Estates, Unit 4,

Niagara Falls, New York

USA, 14305

or email to: service@omcan.com



Purchaser's Information

Name: _____

Address: _____

City: _____ Province or State: _____ Postal or Zip: _____

Country: _____

Dealer from which Purchased: _____

Dealer City: _____ Dealer Province or State: _____

Invoice: _____

Model Name: _____ Model Number: _____

Machine Description: _____

Date of Purchase (MM/DD/YYYY): _____

Would you like to extend the warranty? Yes No

Company Name: _____

Telephone: _____

Email Address: _____

Type of Company:

Restaurant Bakery Deli

Butcher Supermarket Caterer

Institution (specify): _____

Other (specify): _____

Serial Number: _____

Date of Installation (MM/DD/YYYY): _____

Thank you for choosing Omcan | Merci d'avoir choisi Omcan | Gracias por elegir Omcan



Since 1951 Omcan has grown to become a leading distributor of equipment and supplies to the North American food service industry. Our success over these many years can be attributed to our commitment to strengthen and develop new and existing relationships with our valued customers and manufacturers. Today with partners in North America, Europe, Asia and South America, we continually work to improve and grow the company. We strive to offer customers exceptional value through our qualified local sales and service representatives who provide convenient access to over 6,500 globally sourced products.

Depuis 1951 Omcan a grandi pour devenir un des “leaders” de la distribution des équipements et matériel pour l’industrie des services alimentaires en Amérique du Nord. Notre succès au cours de ces nombreuses années peut être attribué à notre engagement à renforcer et à développer de nouvelles et existantes relations avec nos clients et les fabricants de valeur. Aujourd’hui avec des partenaires en Amérique du Nord, Europe, Asie et Amérique du Sud, nous travaillons continuellement à améliorer et développer l’entreprise. Nous nous efforçons d’offrir à nos clients une valeur exceptionnelle grâce à nos ventes locales qualifiées et des représentants de service qui offrent un accès facile à plus de 6500 produits provenant du monde entier.

Desde 1951 Omcan ha crecido hasta convertirse en un líder en la distribución de equipos y suministros de alimentos en América del Norte industria de servicios. Nuestro éxito en estos años se puede atribuir a nuestro compromiso de fortalecer y desarrollar nuevas relaciones existentes con nuestros valiosos clientes y fabricantes. Hoy con socios de América del Norte, Europa, Asia y América del Sur, que trabajan continuamente para mejorar y crecer la empresa. Nos esforzamos por ofrecer a nuestros clientes valor excepcional a través de nuestro local de ventas y representantes de los servicios que proporcionan un fácil acceso a más de 6,500 productos con origen a nivel mundial.

